

Features

- 1700-Volt Schottky Rectifier
- Zero Reverse Recovery Current
- Zero Forward Recovery Voltage
- High-Frequency Operation
- Temperature-Independent Switching Behavior
- Extremely Fast Switching
- Halogen-Free; RoHS Compliant

Benefits

- Replace Bipolar with Unipolar Rectifiers
- Essentially No Switching Losses
- Higher Efficiency
- Reduction of Heat Sink Requirements
- Parallel Devices Without Thermal Runaway



V_{RRM}	=	1700 V
$I_F, T_c < 135^\circ C$	=	14.4 A
Q_c	=	96 nC



TO-220-2

Package

Part Number	Package	Marking
C3D10170A	TO-220-2	C3D10170A



Maximum Ratings

Symbol	Parameter	Value	Unit	Test Conditions	Note
V_{RRM}	Repetitive Peak Reverse Voltage	1700	V		
V_{RSM}	Surge Peak Reverse Voltage	1700	V		
V_{DC}	DC Blocking Voltage	1700	V		
I_F	Continuous Forward Current	14.4	A	$T_c < 135^\circ C$	
I_{FRM}	Repetitive Peak Forward Surge Current	45 26	A	$T_c = 25^\circ C, t_p = 10 \text{ ms}, \text{Half Sine Wave}, D = 1$ $T_c = 110^\circ C, t_p = 10 \text{ ms}, \text{Half Sine Wave}, D = 1$	
I_{FSM}	Non-Repetitive Peak Forward Surge Current	55 41	A	$T_c = 25^\circ C, t_p = 10 \text{ ms}, \text{Half Sine Wave}, D = 1$ $T_c = 110^\circ C, t_p = 10 \text{ ms}, \text{Half Sine Wave}, D = 1$	
P_{tot}	Power Dissipation	231 100	W	$T_c = 25^\circ C$ $T_c = 110^\circ C$	
T_c	Maximum Case Temperature	135	$^\circ C$		
T_j	Operating Junction Range	-55 to +175	$^\circ C$		
T_{stg}	Storage Temperature Range	-55 to +135	$^\circ C$		
	TO-247 Mounting Torque	1 8.8	Nm lbf-in	M3 Screw 6-32 Screw	

Electrical Characteristics

Symbol	Parameter	Typ.	Max.	Unit	Test Conditions	Note
V_F	Forward Voltage	1.7 3	2 3.5	V	$I_F = 10\text{ A}$ $T_J = 25^\circ\text{C}$ $I_F = 10\text{ A}$ $T_J = 175^\circ\text{C}$	
I_R	Reverse Current	20 100	60 300	μA	$V_R = 1700\text{ V}$ $T_J = 25^\circ\text{C}$ $V_R = 1700\text{ V}$ $T_J = 175^\circ\text{C}$	
Q_C	Total Capacitive Charge	96		nC	$V_R = 1700\text{ V}$, $I_F = 10\text{ A}$ $di/dt = 200\text{ A}/\mu\text{s}$ $T_J = 25^\circ\text{C}$	
C	Total Capacitance	827 78 41		pF	$V_R = 0\text{ V}$, $T_J = 25^\circ\text{C}$, $f = 1\text{ MHz}$ $V_R = 200\text{ V}$, $T_J = 25^\circ\text{C}$, $f = 1\text{ MHz}$ $V_R = 800\text{ V}$, $T_J = 25^\circ\text{C}$, $f = 1\text{ MHz}$	

Note:

1. This is a majority carrier diode, so there is no reverse recovery charge.

Thermal Characteristics

Symbol	Parameter	Typ.	Unit
$R_{\theta JC}$	Thermal Resistance from Junction to Case	0.65	$^\circ\text{C}/\text{W}$

Typical Performance

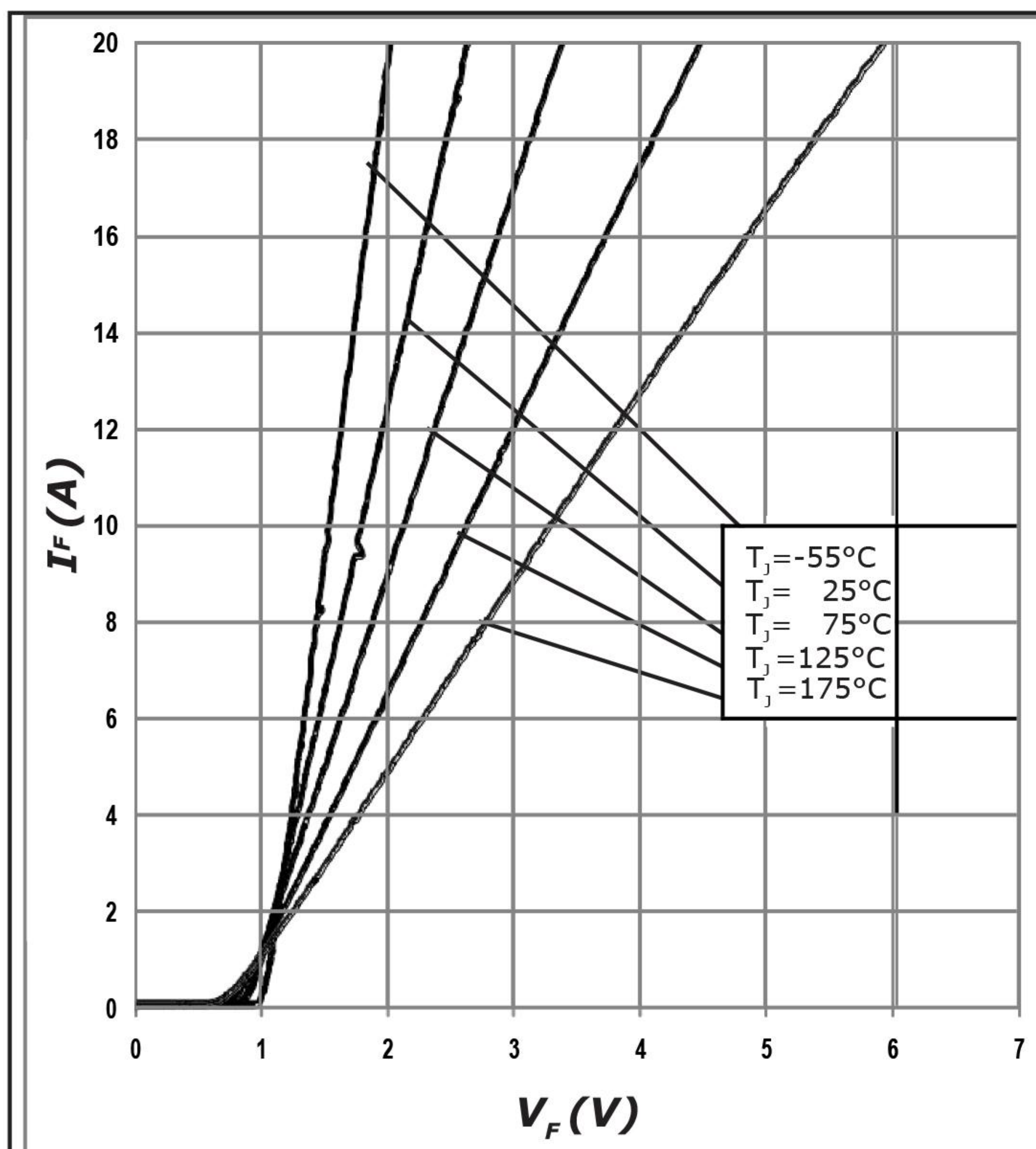

Figure 1. Forward Characteristics

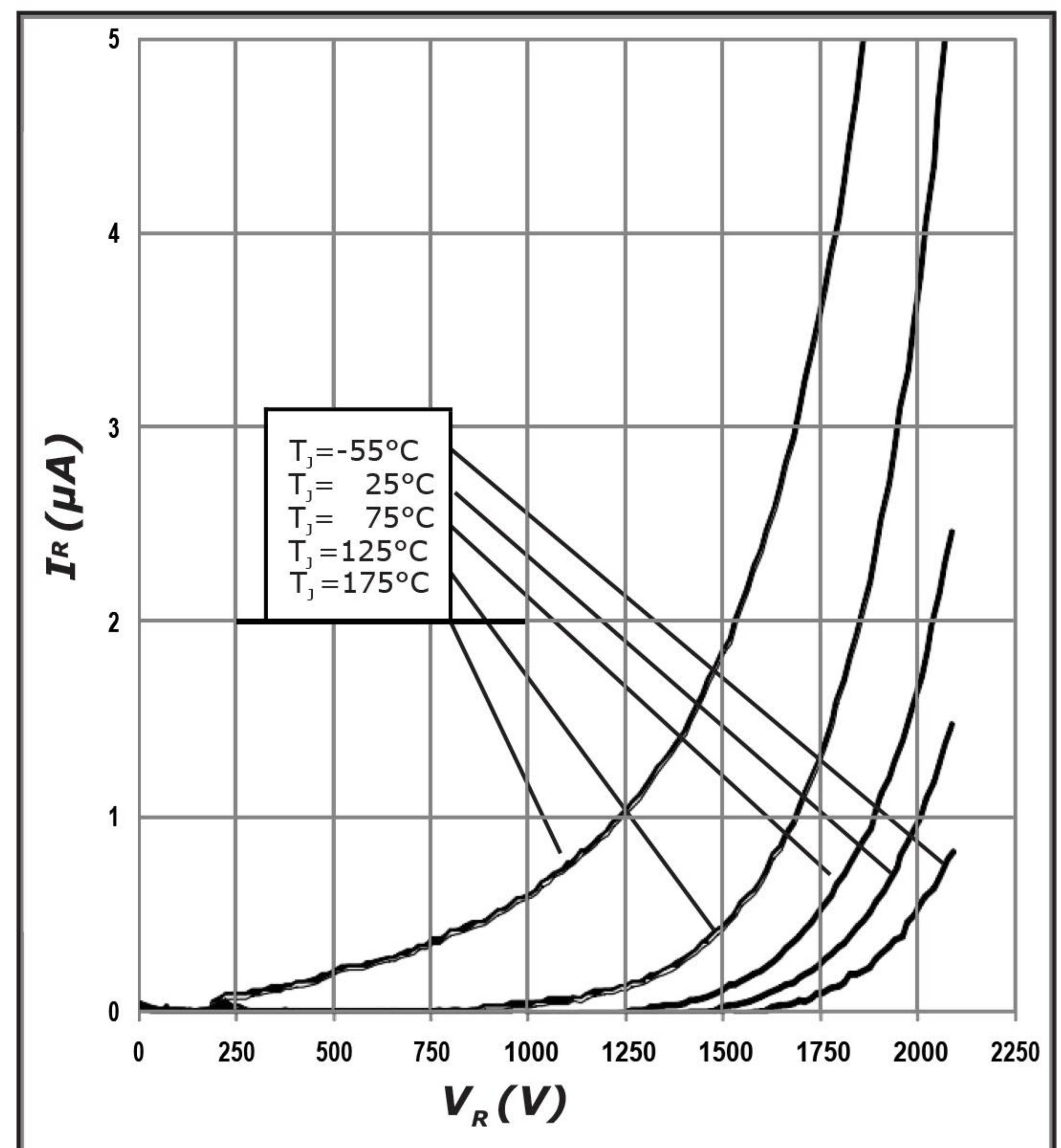

Figure 2. Reverse Characteristics

Typical Performance

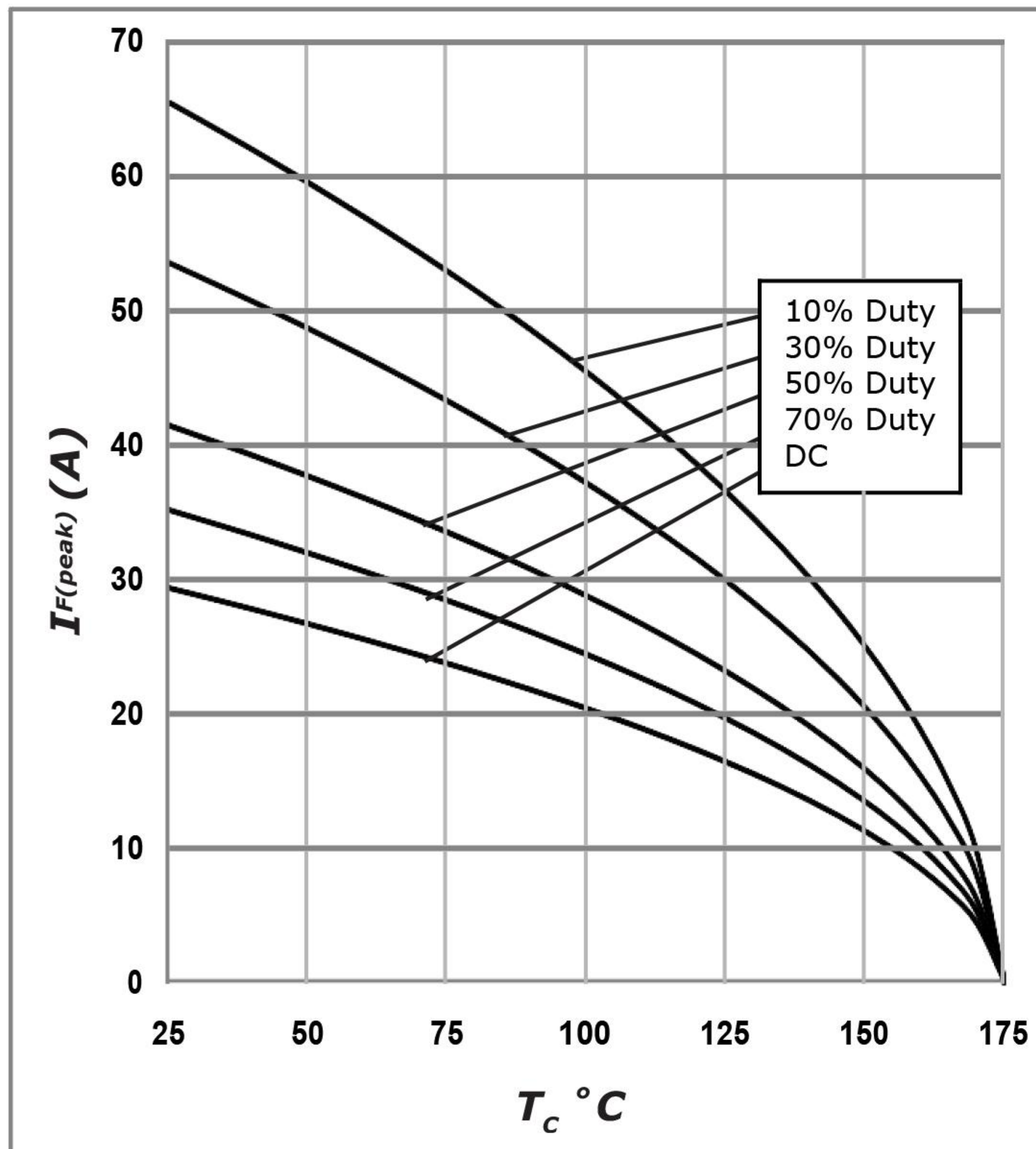

Figure 3. Current Derating

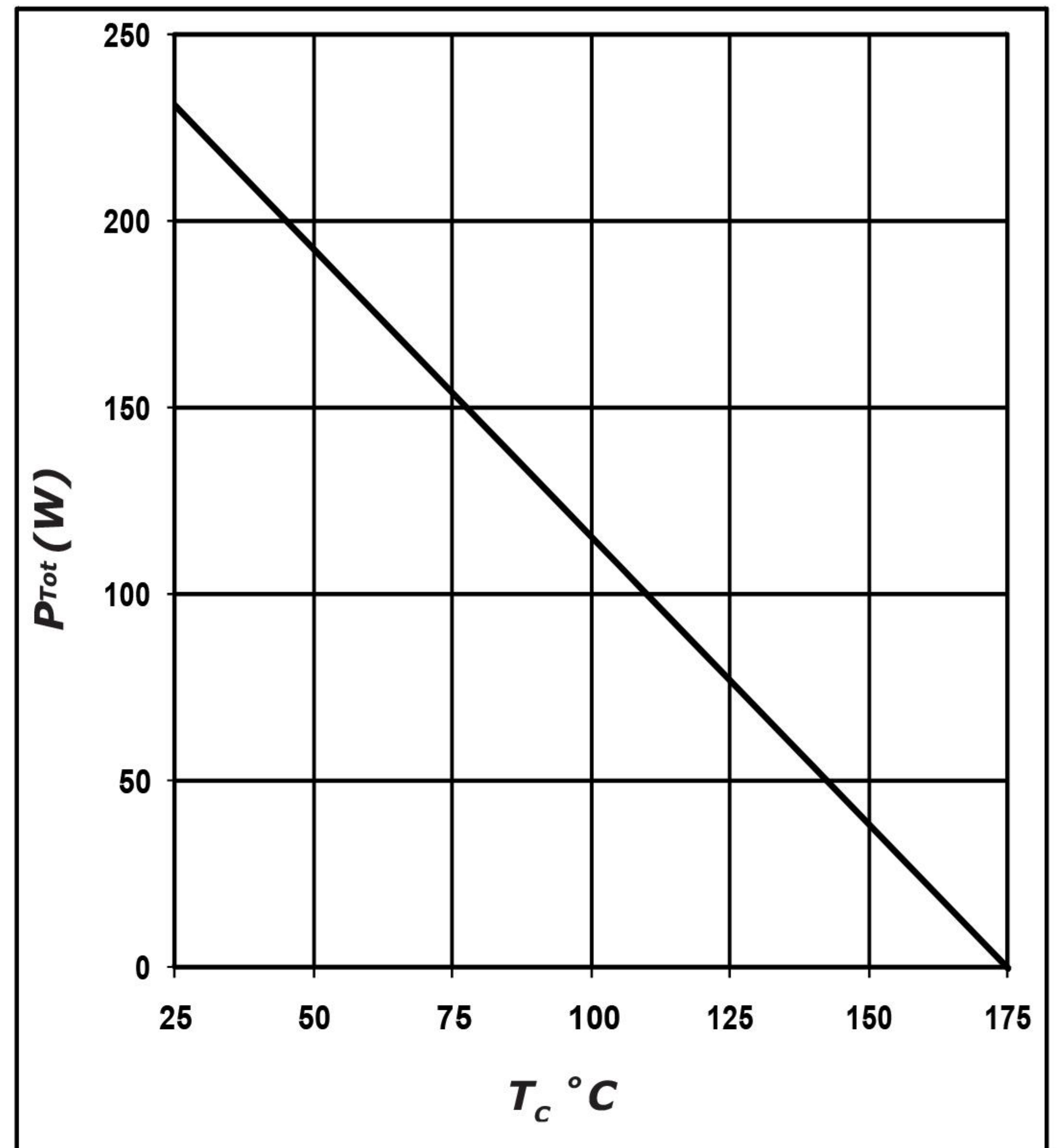

Figure 4. Power Derating

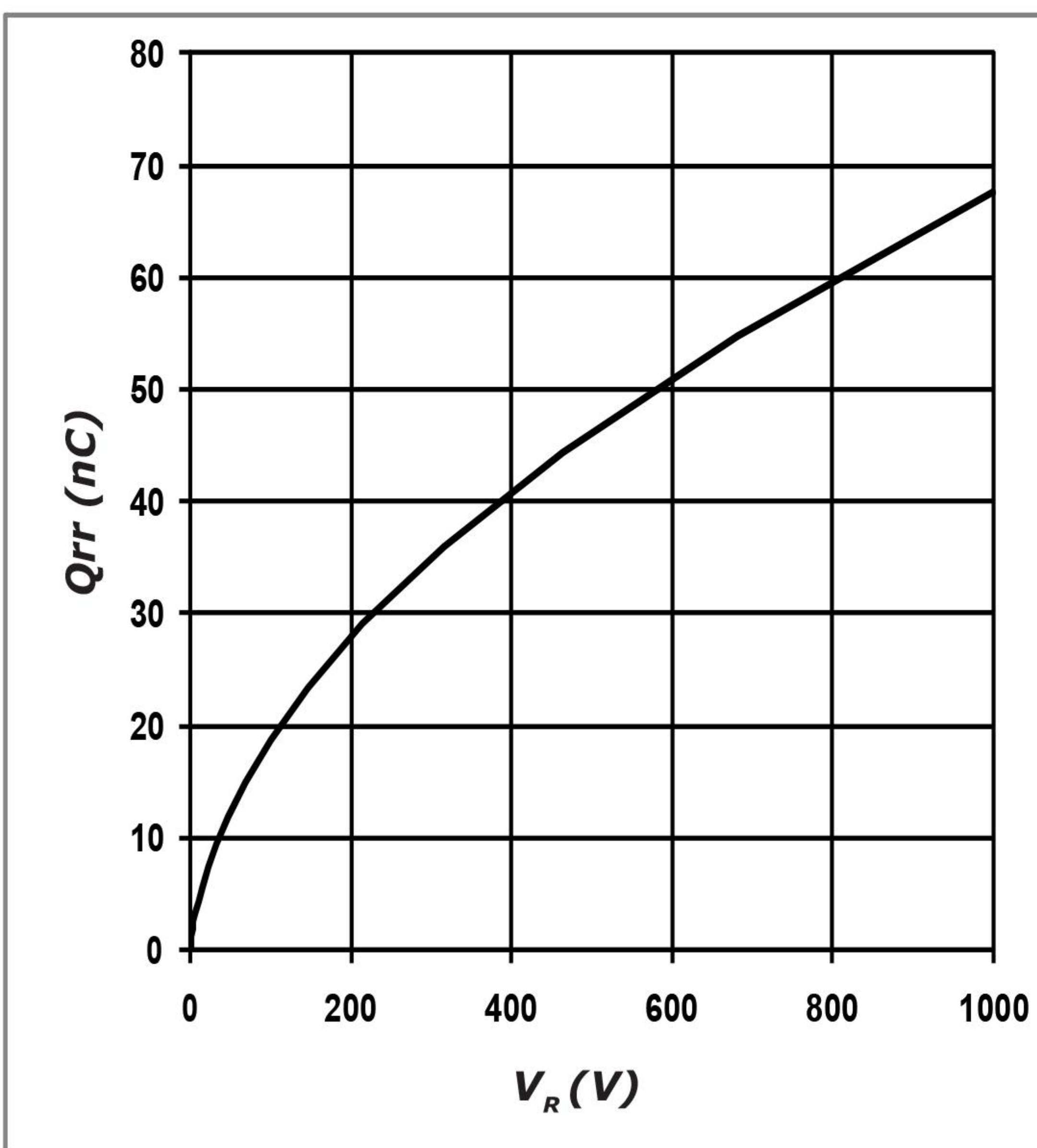

Figure 5. Recovery Charge vs. Reverse Voltage

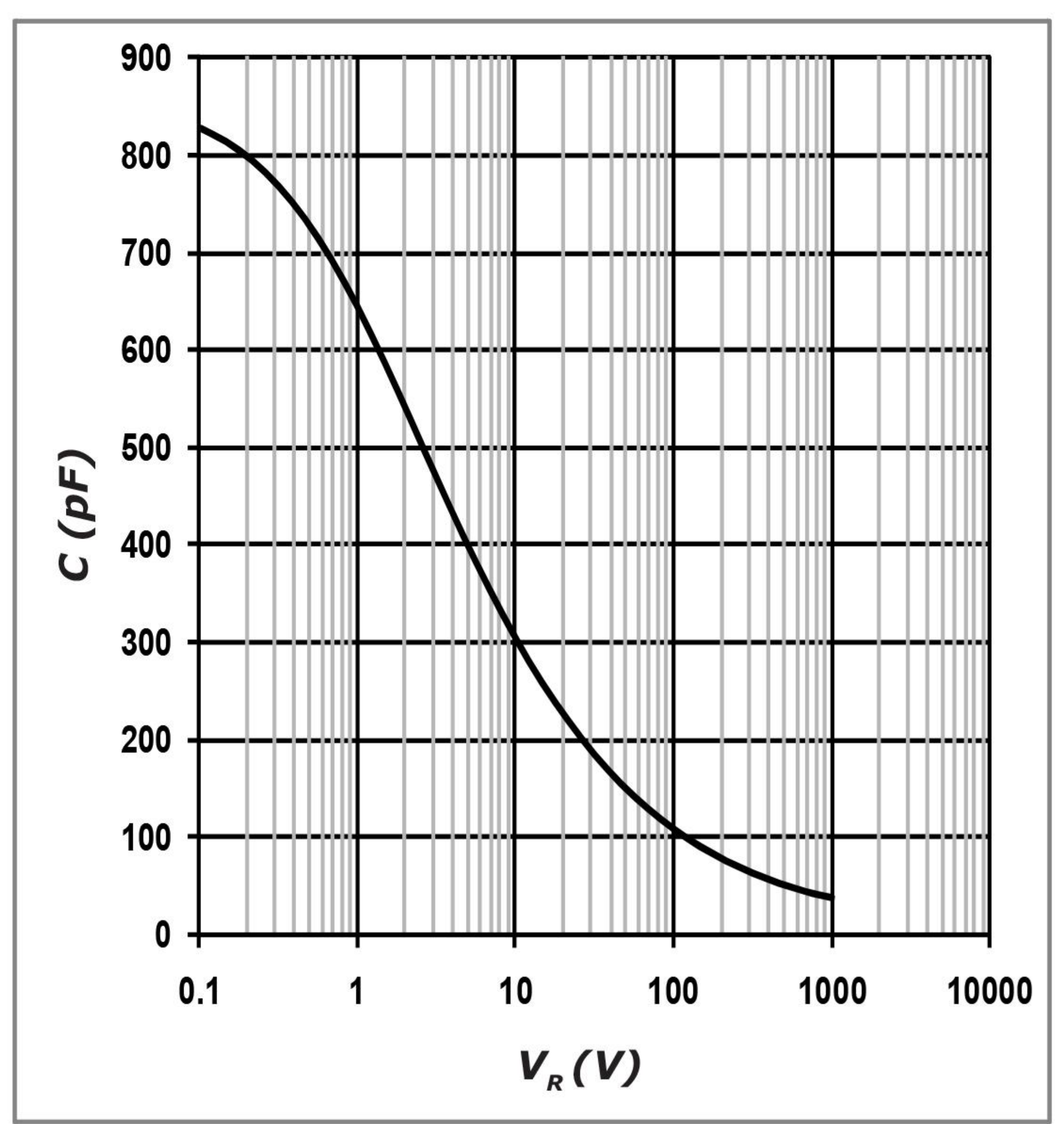

Figure 6. Capacitance vs. Reverse Voltage

Typical Performance

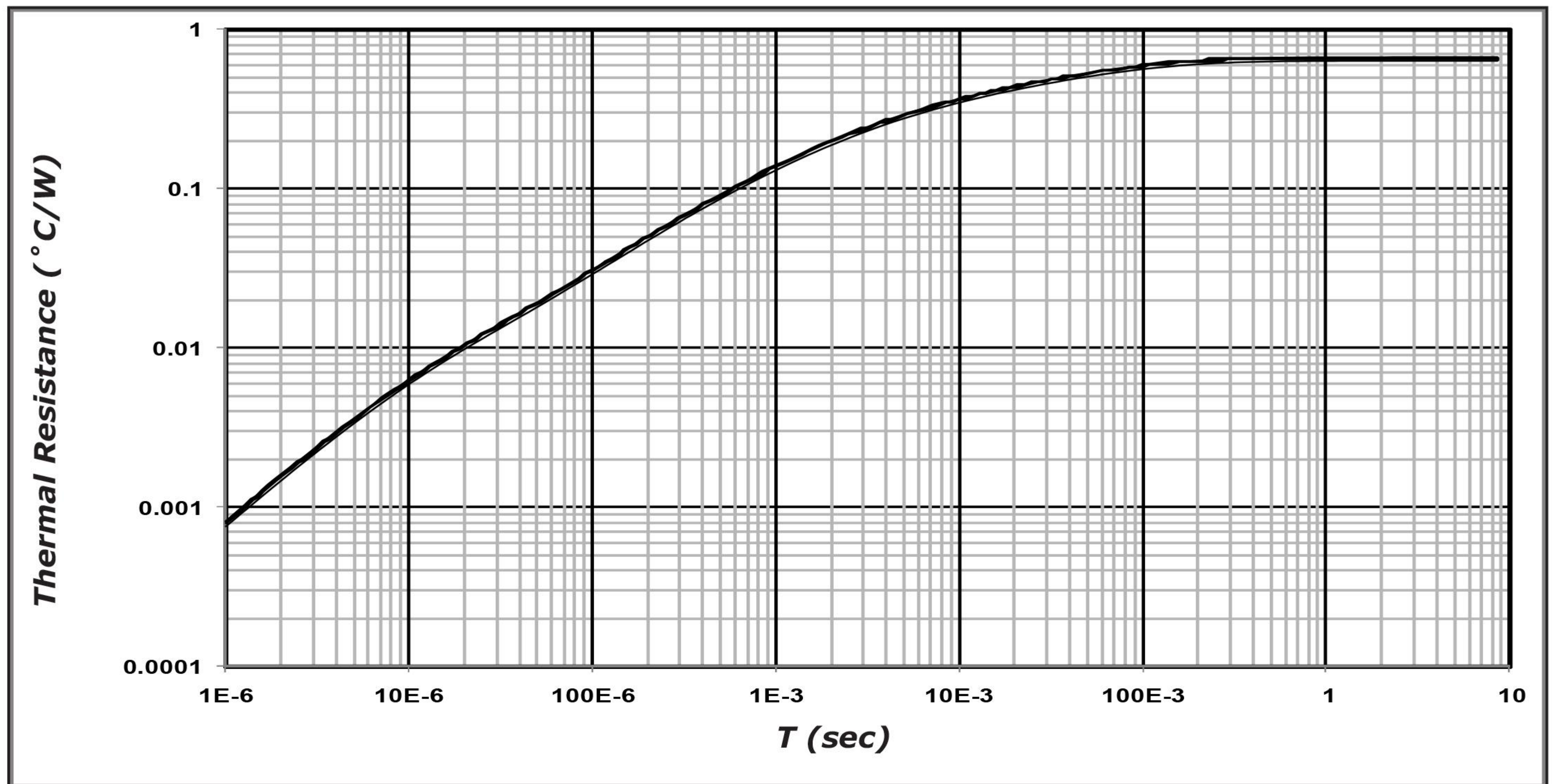
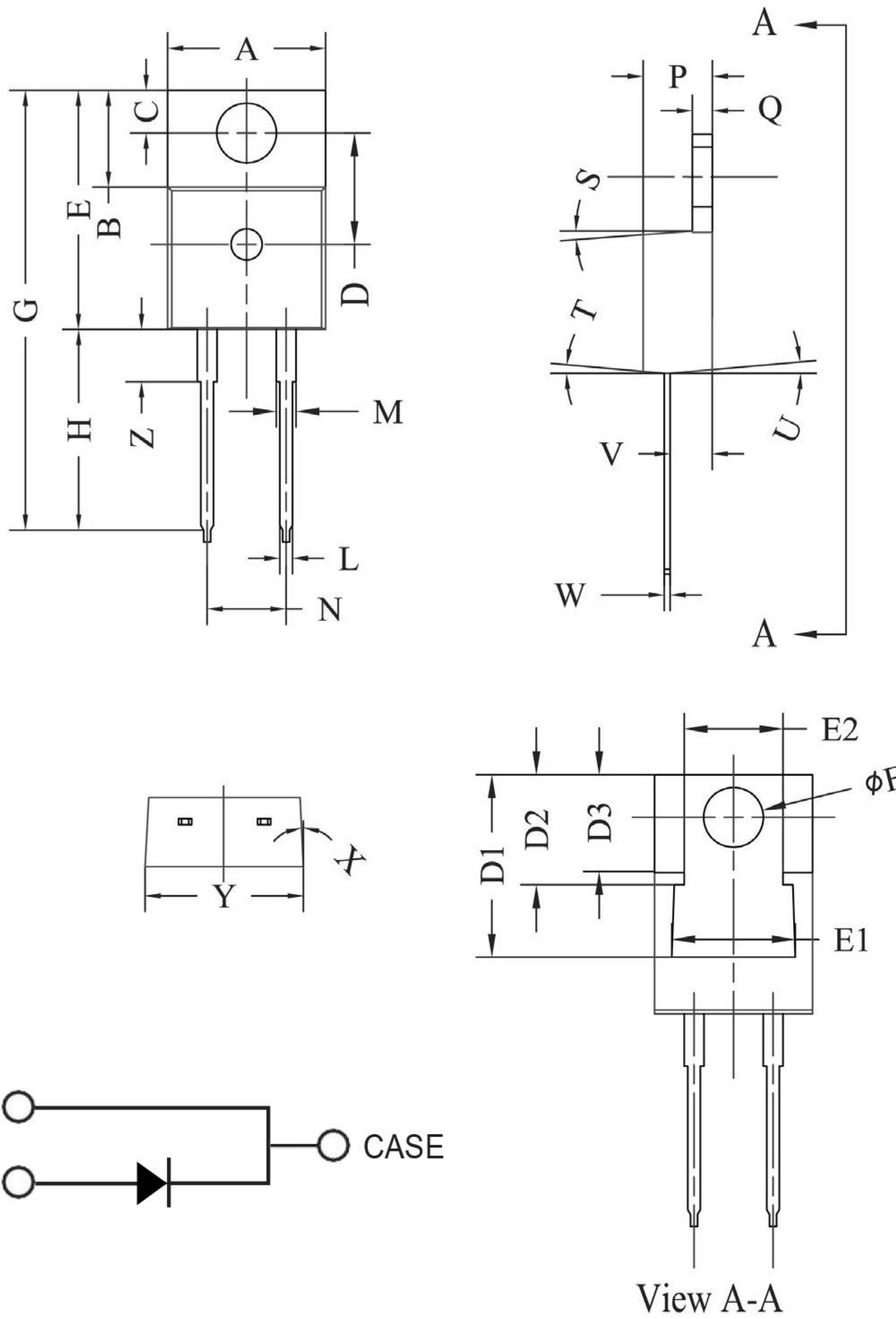

Figure 7. Transient Thermal Impedance

Package Dimensions

Package TO-220-2



POS	Inches		Millimeters	
	Min	Max	Min	Max
A	.381	.410	9.677	10.414
B	.235	.255	5.969	6.477
C	.100	.120	2.540	3.048
D	.223	.337	5.664	8.560
D1	.457-.490		11.60-12.45 typ	
D2	.277-.303 typ		7.04-7.70 typ	
D3	.244-.252 typ		6.22-6.4 typ	
E	.590	.615	14.986	15.621
E1	.302	.326	7.68	8.28
E2	.227	.251	5.77	6.37
F	.143	.153	3.632	3.886
G	1.105	1.147	28.067	29.134
H	.500	.550	12.700	13.970
L	.025	.036	.635	.914
M	.045	.055	1.143	1.550
N	.195	.205	4.953	5.207
P	.165	.185	4.191	4.699
Q	.048	.054	1.219	1.372
S	3°	6°	3°	6°
T	3°	6°	3°	6°
U	3°	6°	3°	6°
V	.094	.110	2.388	2.794
W	.014	.025	.356	.635
X	3°	5.5°	3°	5.5°
Y	.385	.410	9.779	10.414
Z	.130	.150	3.302	3.810

Diode Model

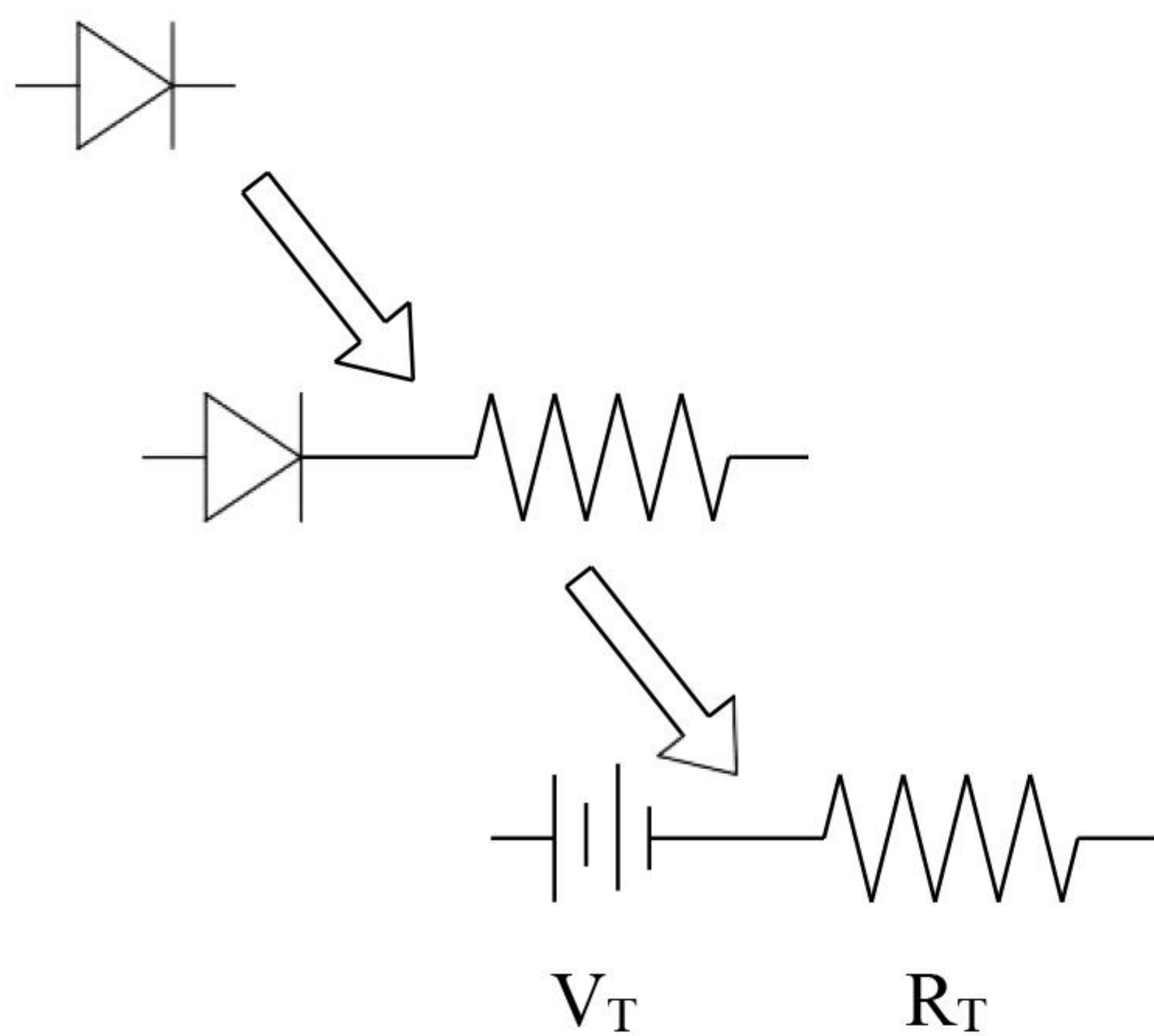

$$V_{fT} = V_T + I_f * R_T$$

$$V_T = 0.975 + (T_j * -1.4 * 10^{-3})$$

$$R_T = 0.053 + (T_j * 1.1 * 10^{-3})$$

Note: T_j = Diode Junction Temperature In Degrees Celcius