

KBPC50005 THRU KBPC5010 SINGLE PHASE 50.0 AMP BRIDGE RECTIFIERS

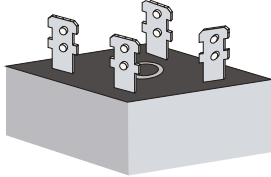

FEATURES

- * Superior thermal design
- * 400 amperes surge capability
- * Mounting: Hole thru for #8 screw
- * 1/4" universal faston terminal

VOLTAGE RANGE

50 to 1000 Volts

CURRENT

50.0 Ampere

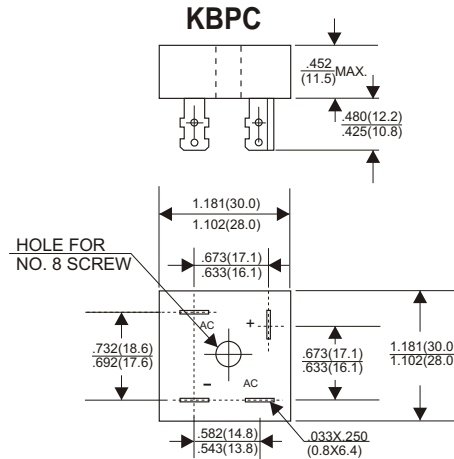

MAXIMUM RATINGS AND ELECTRICAL CHARACTERISTICS

Rating 25°C ambient temperature unless otherwise specified.
Single phase half wave, 60Hz, resistive or inductive load.
For capacitive load, derate current by 20%.

TYPE NUMBER	KBPC50005	KBPC5001	KBPC5002	KBPC5004	KBPC5006	KBPC5008	KBPC5010	UNITS	
Maximum Recurrent Peak Reverse Voltage	50	100	200	400	600	800	1000	V	
Maximum RMS Voltage	35	70	140	280	420	560	700	V	
Maximum DC Blocking Voltage	50	100	200	400	600	800	1000	V	
Maximum Average Forward Rectified Current .375"(9.5mm) Lead Length at Tc=50°C								50.0	A
Peak Forward Surge Current, 8.3 ms single half sine-wave superimposed on rated load (JEDEC method)								450	A
Maximum Forward Voltage Drop per Bridge Element at 25A D.C.								1.2	V
Maximum DC Reverse Current at Rated DC Blocking Voltage								10	µA
Operating Temperature Range, Tj								-65 — +150	°C
Storage Temperature Range, Tstg								-65 — +150	°C

RATING AND CHARACTERISTIC CURVES (KBPC50005 THRU KBPC5010)

FIG.1-TYPICAL FORWARD CURRENT DERATING CURVE

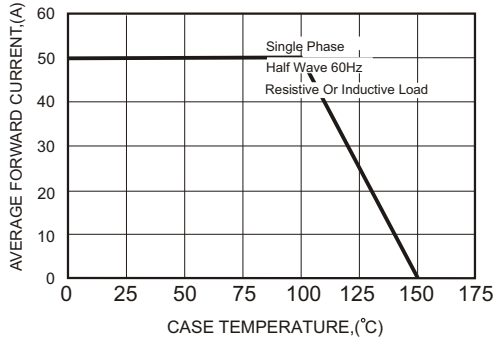

FIG.2-MAXIMUM NON-REPETITIVE FORWARD SURGE CURRENT

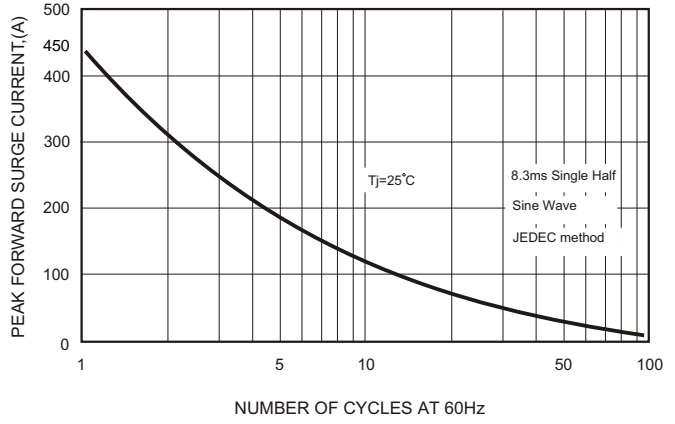

FIG.3-TYPICAL FORWARD CHARACTERISTICS

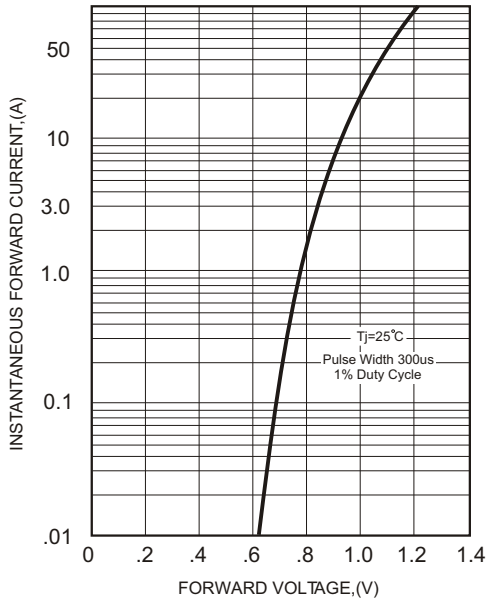

FIG.4-TYPICAL REVERSE CHARACTERISTICS

