

## MUR805 THRU MUR8100 8.0 AMP SUPER FAST RECTIFIERS

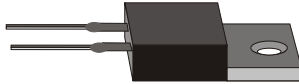

### FEATURES

- \* Low forward voltage drop
- \* High current capability
- \* High reliability
- \* High surge current capability
- \* Good for switching mode application

### MECHANICAL DATA

- \* Case: Molded plastic
- \* Epoxy: UL 94V-0 rate flame retardant
- \* Lead: Lead solderable per MIL-STD-202, method 208 guaranteed
- \* Polarity: As Marked
- \* Mounting position: Any

### VOLTAGE RANGE

50 to 1000 Volts

### CURRENT

8.0 Amperes

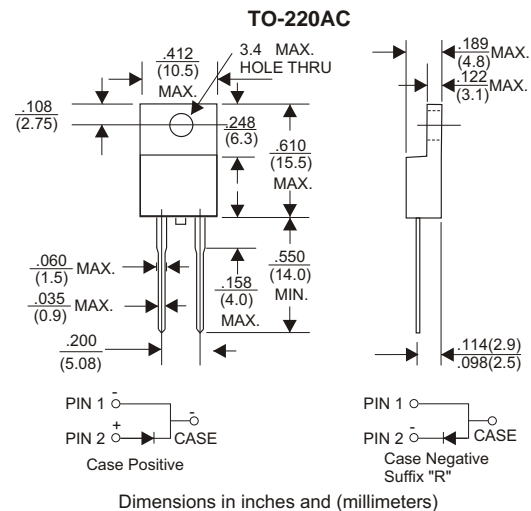

### MAXIMUM RATINGS AND ELECTRICAL CHARACTERISTICS

Rating 25°C ambient temperature unless otherwise specified.  
Single phase half wave, 60Hz, resistive or inductive load.  
For capacitive load, derate current by 20%.

| TYPE NUMBER   | MUR805     | MUR810 | MUR820 | MUR830 | MUR840 | MUR860 | MUR880 | MUR8100 | UNITS |
|---|------------|--------|--------|--------|--------|--------|--------|---------|-------|
| Maximum Recurrent Peak Reverse Voltage  | 50         | 100    | 200    | 300    | 400    | 600    | 800    | 1000    | V     |
| Maximum RMS Voltage   | 35         | 70     | 140    | 210    | 280    | 420    | 560    | 700     | V     |
| Maximum DC Blocking Voltage   | 50         | 100    | 200    | 300    | 400    | 600    | 800    | 1000    | V     |
| Maximum Average Forward Rectified Current<br>.375"(9.5mm) Lead Length at Ta=50°C                      | 8.0        |        |        |        |        |        |        |         | A     |
| Peak Forward Surge Current, 8.3 ms single half sine-wave<br>superimposed on rated load (JEDEC method) | 175        |        |        |        |        |        |        |         | A     |
| Maximum Instantaneous Forward Voltage at 8.0A   | 1.0        |        | 1.3    |        | 1.75   |        |        |         | V     |
| Maximum DC Reverse Current Ta=25°C  | 10         |        |        |        |        |        |        |         | µA    |
| at Rated DC Blocking Voltage Ta=100°C   | 200        |        |        |        |        |        |        |         | µA    |
| Maximum Reverse Recovery Time (Note 1)  | 50         |        |        |        |        |        |        |         | nS    |
| Typical Junction Capacitance (Note 2)   | 50         |        |        |        |        |        |        |         | pF    |
| Operating and Storage Temperature Range Tj, Tstg  | -65 — +150 |        |        |        |        |        |        |         | °C    |

#### NOTES:

- Reverse Recovery Time test condition: IF=0.5A, IR=1.0A, IRR=0.25A
- Measured at 1MHz and applied reverse voltage of 4.0V D.C.

## RATING AND CHARACTERISTIC CURVES (MUR805 THRU MUR8100)

FIG.1- TEST CIRCUIT DIAGRAM AND REVERSE RECOVERY TIME CHARACTERISTIC

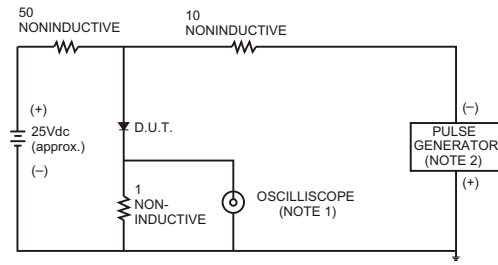

NOTES: 1. Rise Time= 7ns max., Input Impedance= 1 megohm, 22pF.  
2. Rise Time= 10ns max., Source Impedance= 50 ohms.

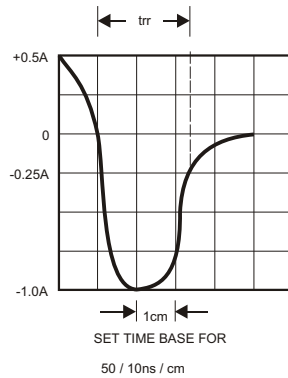

FIG.2-TYPICAL FORWARD CURRENT DERATING CURVE

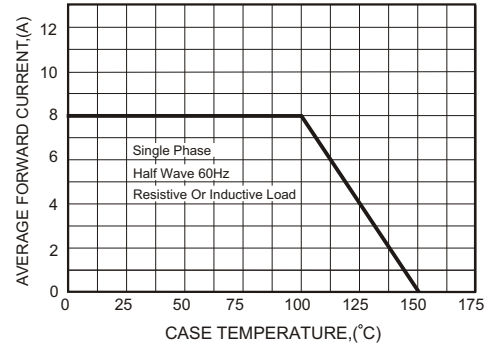

FIG.3-TYPICAL FORWARD CHARACTERISTICS

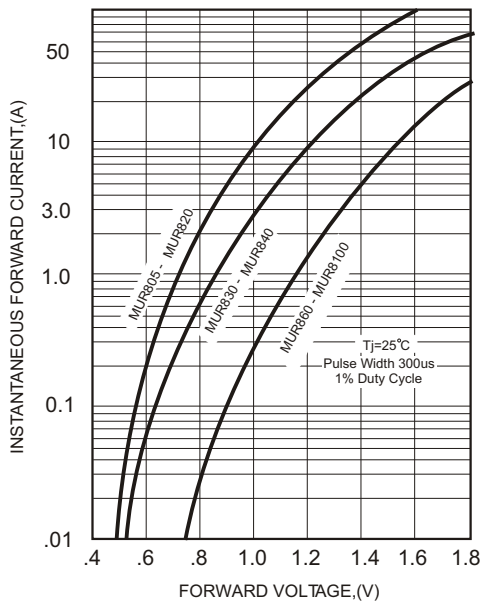

FIG.4-TYPICAL REVERSE CHARACTERISTICS

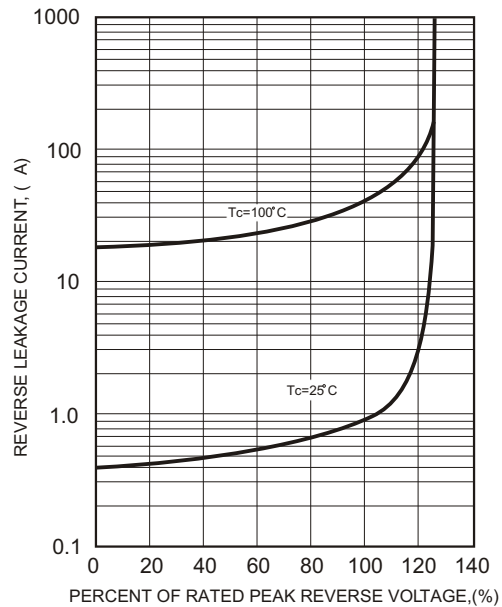

FIG.5-MAXIMUM NON-REPETITIVE FORWARD SURGE CURRENT

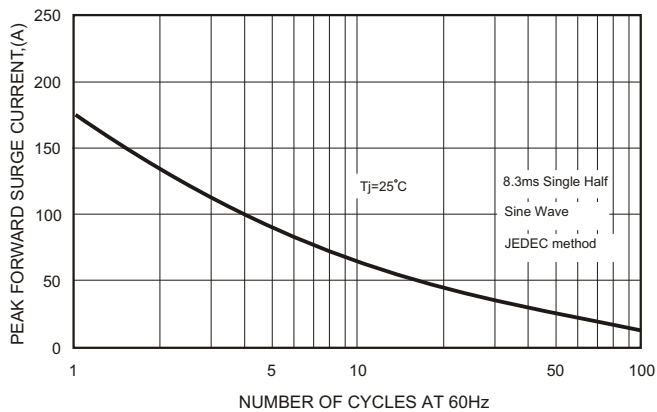

FIG.6-TYPICAL JUNCTION CAPACITANCE

