



SB2045 THRU SB20100

20.0 AMP SCHOTTKY BARRIER RECTIFIERS



■ Features

- Low forward voltage drop.
- Excellent high temperature stability.
- Fast switching capability.
- Suffix "G" indicates Halogen-free part, ex. CP10S45SG.
- Lead-free parts meet environmental standards of MIL-STD-19500 /228

■ Mechanical data

- Epoxy : UL94-V0 rated flame retardant.
- Case : Molded plastic, TO-277.
- Lead : Solder plated, solderable per MIL-STD-750, Method 2026.
- Polarity: Indicated by cathode band.
- Mounting Position : Any.
- Weight : Approximated 0.093 grams.

VOLTAGE RANGE 45 -100 Volts
CURRENT 20.0 Ampere

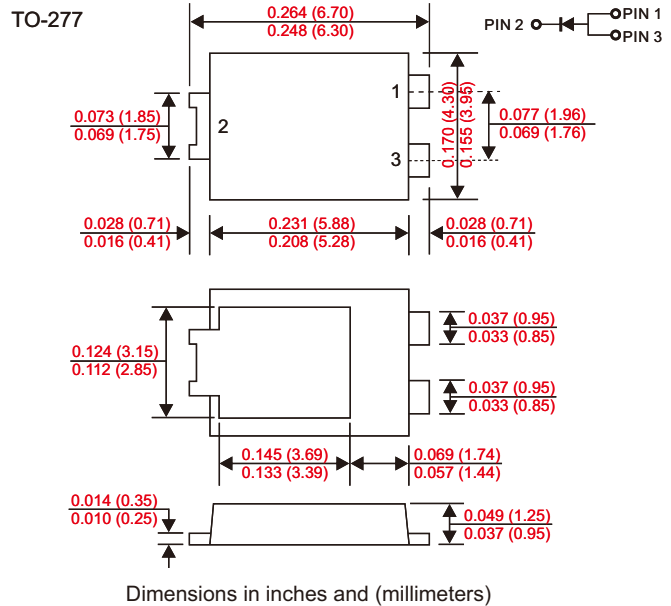

MAXIMUM RATINGS AND ELECTRICAL CHARACTERISTICS

Rating 25 °C ambient temperature unless otherwise specified.
 Single phase half wave, 60Hz, resistive or inductive load.
 For capacitive load, derate current by 20%.

TYPE NUMBER	SB2045	SB2060	SB20100	UNITS
Maximum Recurrent Peak Reverse Voltage	45	60	100	V
Maximum RMS Voltage	32	42	70	V
Maximum DC Blocking Voltage	45	60	100	V
Maximum Average Forward Rectified Current	20.0			A
See Fig. 1	20.0			A
Peak Forward Surge Current, 8.3 ms single half sine-wave superimposed on rated load (JEDEC method)	200			A
Maximum Instantaneous Forward Voltage at 20.0A	0.55	0.75	0.85	V
Maximum DC Reverse Current Ta=25°C	0.1		0.02	mA
at Rated DC Blocking Voltage Ta=125°C	5		2	mA
Typical Junction Capacitance (Note1)	680			pF
Typical Thermal Resistance R JA (Note 2)	60			°C/W
Operating Temperature Range Tj	—	-55 to +150	—	°C
Storage Temperature Range Tsr	—	-55 to +150	—	°C

Note : 1.FR-4 PCB, 2oz.Copper.
 2.Polyimide PCB, 2oz.Copper.Cathode pad dimensions 18.8mm x 14.4mm.Anode pad dimensions 5.6mm x 14.4mm.

RATING AND VCHARACTERISTIC CURVES(SB2045 THRU SB20100)

FIG.1-TYPICAL FORWARD CURRENT DERATING CURVE

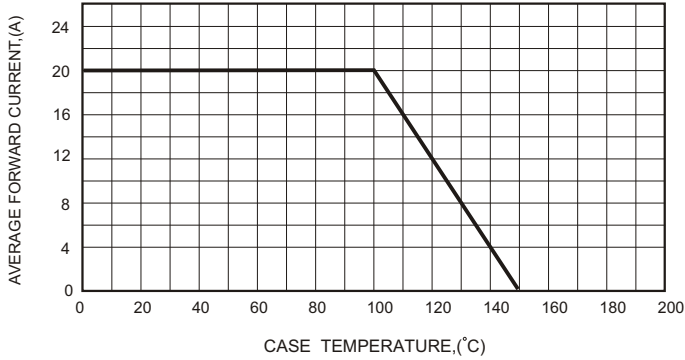

FIG.2-TYPICAL FORWARD CHARACTERISTICS

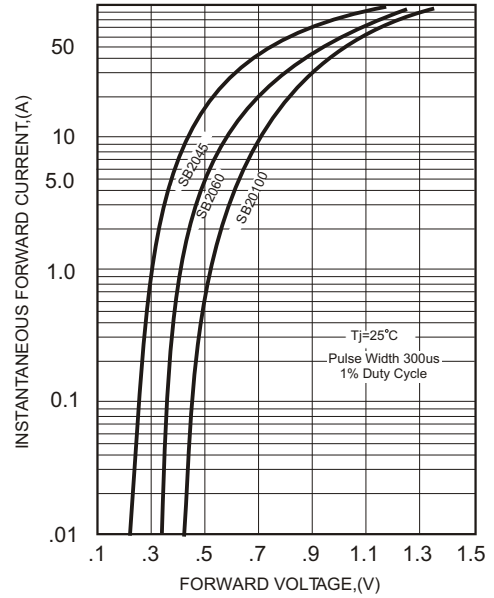

FIG.3-MAXIMUM NON-REPETITIVE FORWARD SURGE CURRENT

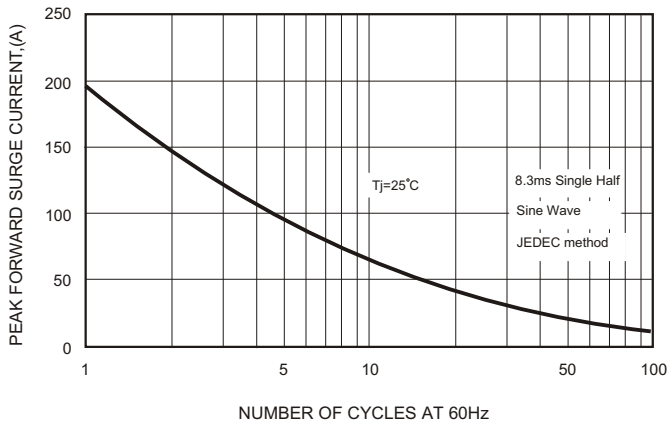

FIG.4-TYPICAL JUNCTION CAPACITANCE

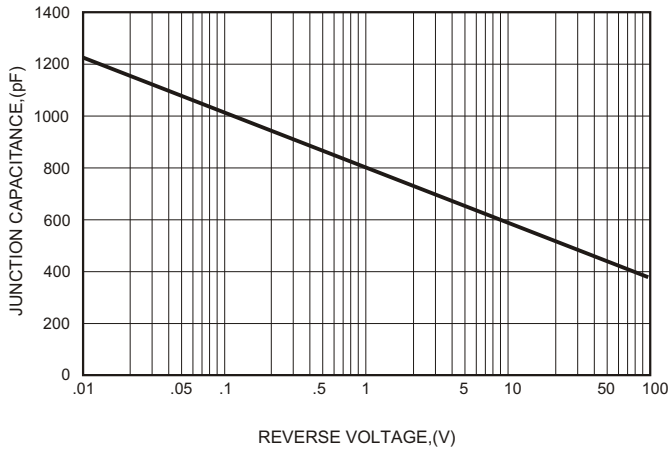

FIG.5 - TYPICAL REVERSE CHARACTERISTICS

