

Features

- Low profile space
- Ideal for automated placement
- Glass passivated chip junction
- Low forward voltage drop
- Low leakage current
- High forward surge capability
- High temperature soldering:
260°C/10 seconds at terminals
- Component in accordance to
RoHS 2002/95/1 and WEEE 2002/96/EC

UMB-S



Major Ratings and Characteristics

Major Ratings and Characteristics

| | |
|--------------------|--------------|
| $I_{F(AV)}$ | 0.5 A |
| V_{RRM} | 50V to 1000V |
| I_{FSM} | 20 A |
| I_R | 5.0 μ A |
| V_F | 1.1 V |
| $T_J \text{ max.}$ | 150 °C |

Mechanical Date

- **Case:** TLM-SMolded plastic over glass passivated chip
- **Terminals:** Solder plated, solderable per J-STD-002B and JESD22-B102D
- **Polarity:** Polarity symbols marked on body

Maximum Ratings & Thermal Characteristics ($T_A = 25^\circ\text{C}$ unless otherwise noted)

| Items | Symbol | B1 | B2 | B3 | B4 | B5 | B6 | B7 | UNIT |
|---|--|-------------|-----|-----|-----|-----|-----|------|------|
| Maximum repetitive peak reverse voltage | V_{RRM} | 50 | 100 | 200 | 400 | 600 | 800 | 1000 | V |
| Maximum RMS voltage | V_{RMS} | 35 | 70 | 140 | 280 | 420 | 560 | 700 | V |
| Maximum DC blocking voltage | V_{DC} | 50 | 100 | 200 | 400 | 600 | 800 | 1000 | V |
| Maximum average forward rectified current at $T_A=30^\circ\text{C}$ -on glass-epoxy P.C.B. ⁽¹⁾ -on aluminum substrate ⁽²⁾ | $I_{F(AV)}$ | 0.5 | | | | | | | A |
| Peak forward surge current 8.3 ms single half sine-wave superimposed on rated load (JEDEC Method) | I_{FSM} | 20 | | | | | | | A |
| Thermal resistance from junction to ambient per leg | $R_{\theta JA}^{(1)}$ $R_{\theta JA}^{(2)}$ | 100 80 | | | | | | | °C/W |
| Thermal resistance from junction to lead per leg ⁽¹⁾ | $R_{\theta JL}$ | 30 | | | | | | | °C/W |
| Operating junction and storage temperature range | T_J, T_{STG} | -55 to +150 | | | | | | | °C |

Note 1: On glass epoxy P.C.B. mounted on 0.06×0.04" (1.5×1.1mm) pads

Note 2: On aluminum substrate P.C.B. with an area of 0.8×0.8" (20×20mm) mounted on 0.06×0.04" (1.5×1.1mm) solder pad

Electrical Characteristics ($T_A = 25^\circ\text{C}$ unless otherwise noted)

| Items | Test conditions | Symbol | Min | Type | Max | UNIT |
|---------------------------------------|---|--------|-----|------|----------|---------|
| Instantaneous forward voltage per leg | $I_F=0.4A^{(3)}$ | V_F | - | 0.96 | 1.10 | V |
| Reverse current per leg | $V_R=V_{DC}$ $T_J=25^\circ\text{C}$ $T_J=125^\circ\text{C}$ | I_R | - | - | 5 100 | μ A |

Note 3: Pulse test:300 μ s pulse width,1% duty cycle.

Characteristic Curves ($T_A=25^\circ\text{C}$ unless otherwise noted)

Fig.1 Forward Current Derating Curve

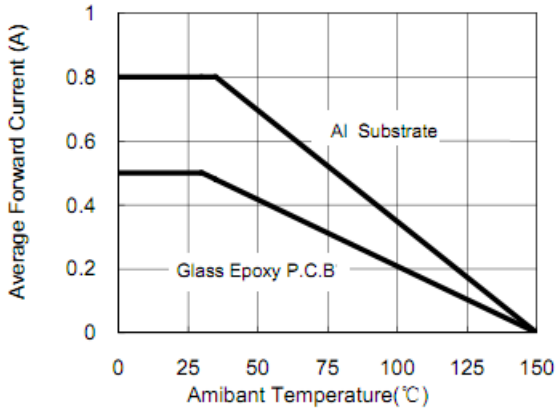

Fig.2 Maximum Non-Repetitive Peak Forward Surge Current

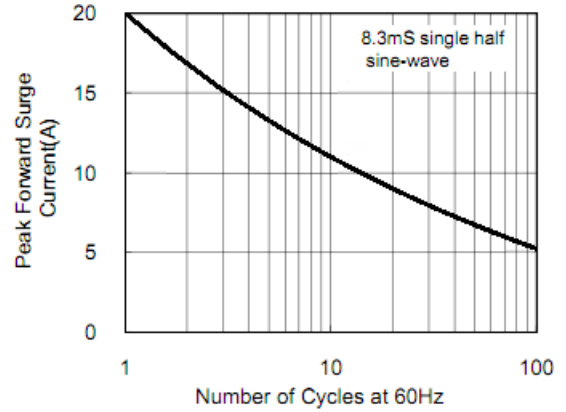

Fig.3 Typical Instantaneous Forward Characteristics

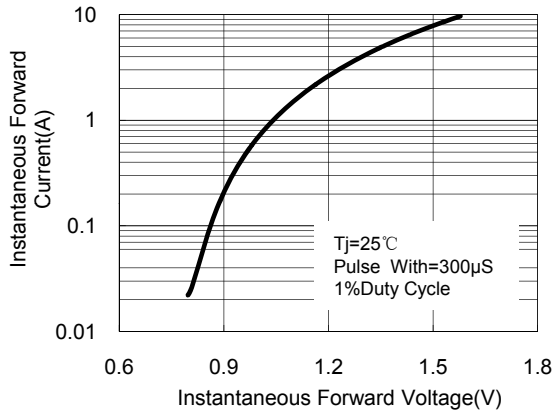
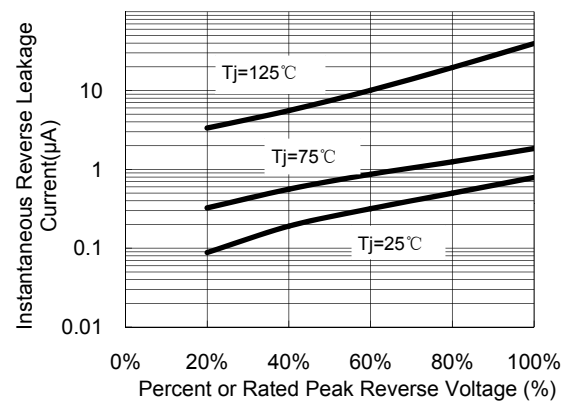
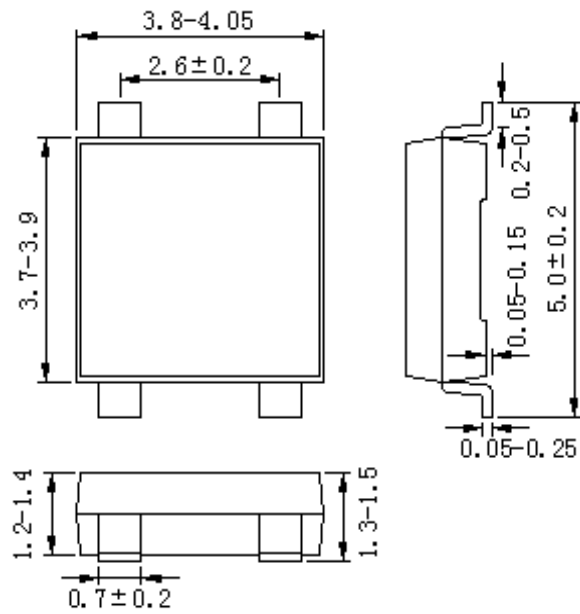

Fig.4 Typical Reverse Leakage Characteristics



Package Outline

UMB-S



Soldering Pad

UMB-S

