

FUZHOU

FQD10N50

500V N-Channel MOSFET.

General Description

This Power MOSFET is produced by OC using its own advanced planar stripe DMOS technology. This advanced technology has been especially tailored to minimize on-state resistance, provide superior switching performance, and withstand high energy pulse in the avalanche and commutation mode. These devices are well suited for high efficiency switched mode power supplies, active power factor correction based on half bridge topology

Features

- 10A, 500V, $R_{DS(on)} = 0.70\Omega @V_{GS} = 10V$
- Low gate charge (typical 19.1 nC) • Low C_{rss} (typical 4.6 pF)
- Fast switching
- 100% avalanche tested
- Improved dv/dt capability

TO-252 Package

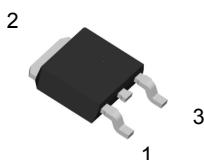

1. Gate 2. Drain 3. Source

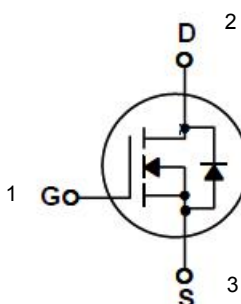

Symbol	Parameter	Value	Units
V_{DSS}	Drain-Source Voltage	500	V
I_D	Drain Current - Continuous (TC= 25°C)	10	A
	- Continuous (TC= 100°C)	6.4*	A
I_{DM}	Drain Current - Pulsed (Note 1)	40*	A
V_{GSS}	Gate-Source Voltage	± 30	V
E_{AS}	Single Pulsed Avalanche Energy (Note 2)	346	mJ
I_{AR}	Avalanche Current (Note 1)	10	A
E_{AR}	Repetitive Avalanche Energy (Note 1)	41	mJ
dv/dt	Peak Diode Recovery dv/dt (Note 3)	5	V/ns
P_D	Power Dissipation (TC = 25°C)	32.5	W
	- Derate above 25°C	0.26	W/°C
T_j, T_{stg}	Operating and Storage Temperature Range	-55 to +150	°C
T_L	Maximum lead temperature for soldering purposes, 1/8" from case for 5 seconds	300	°C

* Drain current limited by maximum junction temperature

Thermal Characteristics

Symbol	Parameter	Value	Units
$R_{\theta JC}$	Thermal Resistance, Junction-to-Case	4.0	°C/W
$R_{\theta JS}$	Thermal Resistance, Case-to-Sink Typ.	--	°C/W
$R_{\theta JA}$	Thermal Resistance, Junction-to-Ambient	47.8	°C/W

Electrical Characteristics TC = 25°C unless otherwise noted

Symbol	Parameter	Test Conditions	Min	Typ	Max	Units
Off Characteristics						
V_{DSS}	Drain-Source Breakdown Voltage	$V_{GS} = 0\text{ V}, I_D = 250\ \mu\text{A}$	500			V
$\Delta V_{DSS} / \Delta T_J$	Breakdown Voltage Temperature Coefficient	$I_D = 250\ \mu\text{A}$, Referenced to 25°C		0.51		V/°C
I_{DSS}	Zero Gate Voltage Drain Current	$V_{DS} = 500\text{ V}, V_{GS} = 0\text{ V}$			1	μA
		$V_{DS} = 400\text{ V}, TC = 125^\circ\text{C}$			10	μA
I_{GSSF}	Gate-Body Leakage Current, Forward	$V_{GS} = 30\text{ V}, V_{DS} = 0\text{ V}$			100	nA
I_{GSSR}	Gate-Body Leakage Current, Reverse	$V_{GS} = -30\text{ V}, V_{DS} = 0\text{ V}$			-100	nA
On Characteristics						
$V_{GS(TH)}$	Gate Threshold voltage	$V_{DS}=V_{GS}, I_D = 250\ \mu\text{A}$		3.2	3.7	V
$R_{DS(On)}$	Drain-Source on-state resistance	$V_{GS}=10\text{ V}, I_D = 5\text{ A}, T_J = 25^\circ\text{C}$		0.70	0.80	Ω
g_{FS}	Forward Transconductance	$V_{DS} = 40\text{ V}, I_D = 5\text{ A}$ (Note 4)		7.5		S
Dynamic Characteristics						
C_{iss}	Input capacitance	$V_{DS} = 25\text{ V}, V_{GS} = 0\text{ V}, f = 1.0\text{ MHz}$		1066		pF
C_{oss}	Output capacitance			153		pF
C_{rss}	Reverse transfer capacitance			4.6		pF
Switching Characteristics						
$t_{d(on)}$	Turn On Delay Time	$V_{DD} = 250\text{ V}, I_D = 10\text{ A}, R_G = 25\ \Omega$ (Note 4, 5)		20		ns
t_r	Rising Time			32		ns
$t_{d(off)}$	Turn Off Delay Time			64		ns
t_f	Fall Time			32		ns
Q_g	Total Gate Charge	$V_{DS} = 400\text{ V}, I_D = 10\text{ A}, V_{GS} = 10\text{ V}$ (Note 4, 5)		19.1		nC
Q_{gs}	Gate-Source Charge			5.5		nC
Q_{gd}	Gate-Drain Charge			6.4		nC
Drain-Source Diode Characteristics and Maximum Ratings						
I_S	Maximum Continuous Drain-Source Diode Forward Current				10	A
I_{SM}	Maximum Pulsed Drain-Source Diode Forward Current				40	A
V_{SD}	Diode Forward Voltage	$V_{GS} = 0\text{ V}, I_S = 10\text{ A}$			1.2	V
t_{rr}	Reverse Recovery Time	$V_{GS} = 0\text{ V}, I_S = 10\text{ A}, di_F / dt = 100\text{ A}/\mu\text{s}$ (Note 4)		320		ns
Q_{rr}	Reverse Recovery Charge			2.2		μC
Notes: 1. Repetitive Rating : Pulse width limited by maximum junction temperature 2. $L = 7.2\text{ mH}, I_{AS} = 10\text{ A}, V_{DD} = 50\text{V}, R_G = 25\ \Omega$, Starting $T_J = 25^\circ\text{C}$ 3. $I_{SD} \leq 10\text{A}, di/dt \leq 200\text{A}/\mu\text{s}, V_{DD} \leq BVDSS$, Starting $T_J = 25^\circ\text{C}$ 4. Pulse Test : Pulse width $\leq 300\mu\text{s}$, Duty cycle $\leq 2\%$ 5. Essentially independent of operating temperature						

Typical Characteristics

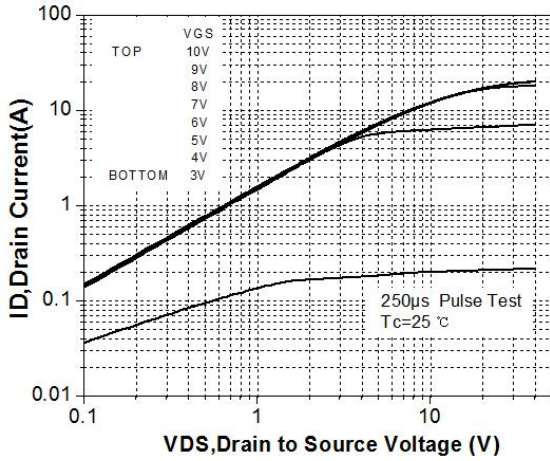

Figure 1. On-Region Characteristics

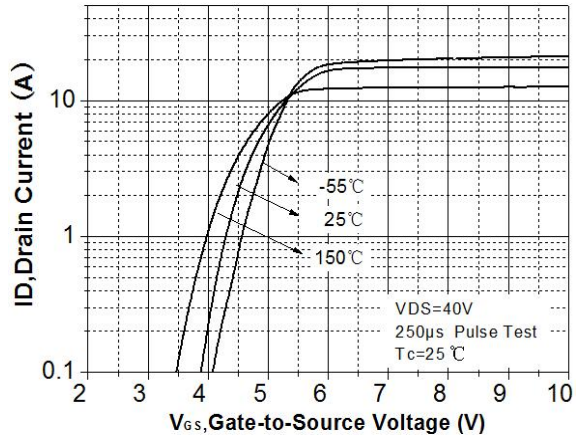

Figure 2. Transfer Characteristics

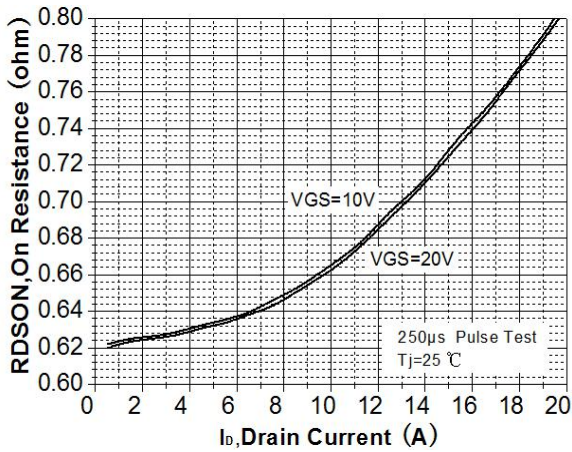

Figure 3. On-Resistance Variation vs Drain Current and Gate Voltage

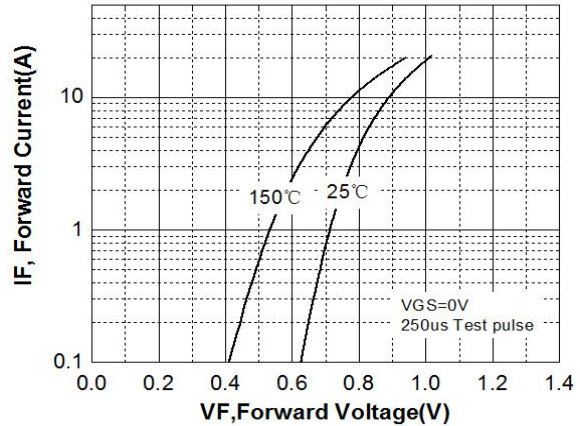

Figure 4. Body Diode Forward Voltage Variation with Source Current and Temperature

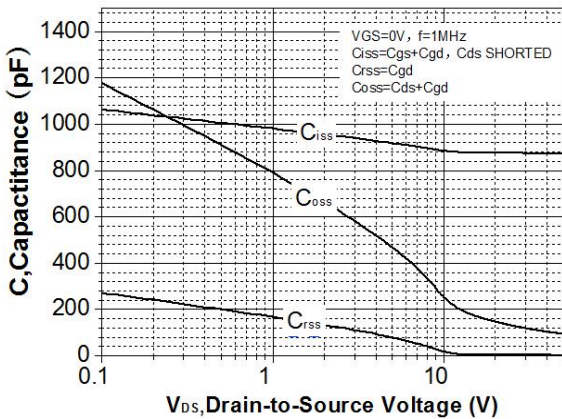

Figure 5. Capacitance Characteristics

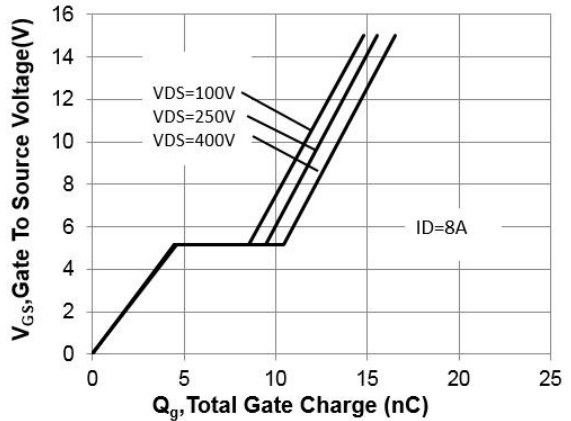

Figure 6. Gate Charge Characteristics

Typical Characteristics (Continued)

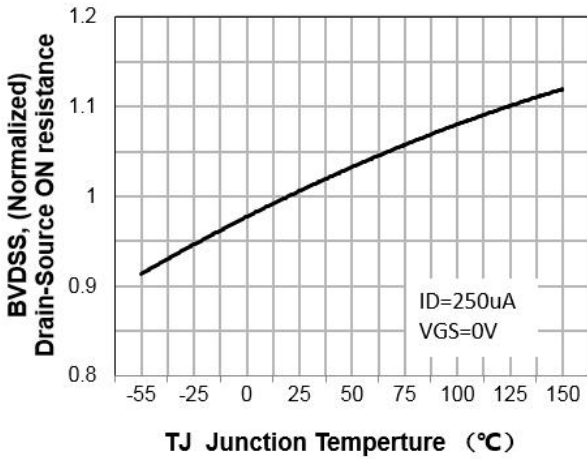

Figure 7. Breakdown Voltage Variation vs Temperature

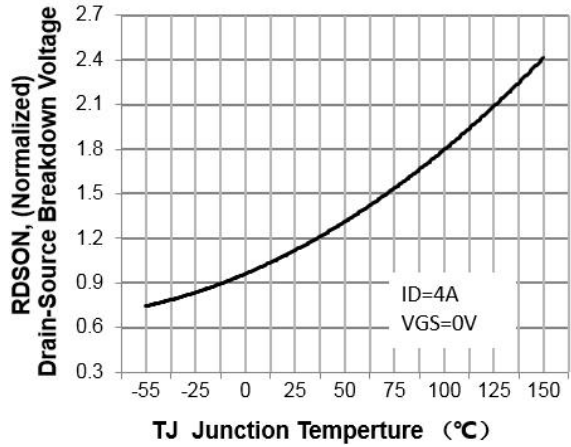

Figure 8. On-Resistance Variation vs Temperature

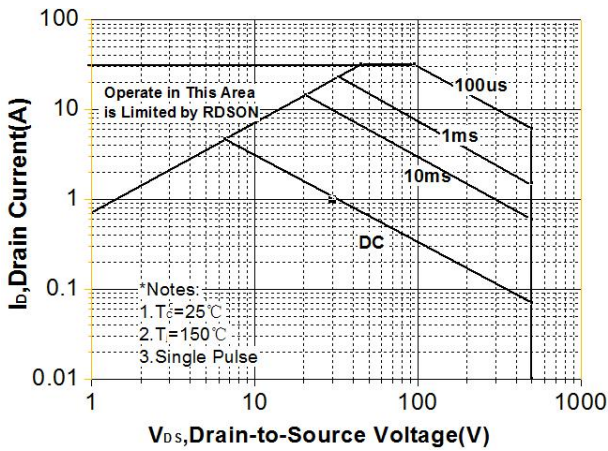

Figure 9. Maximum Safe Operating Area

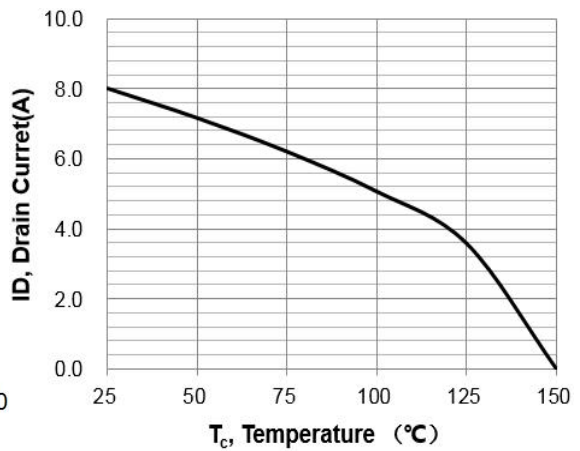

Figure 10. Maximum Drain Current vs Case Temperature

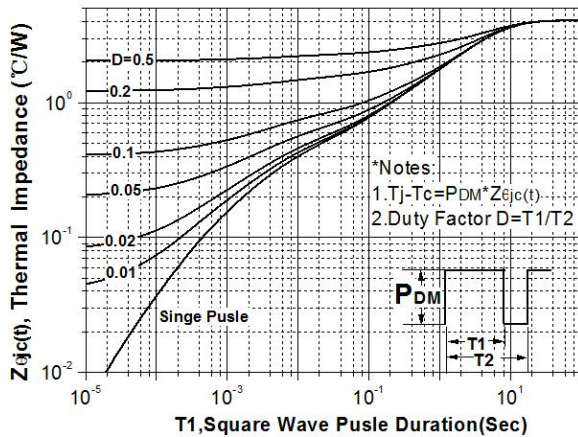
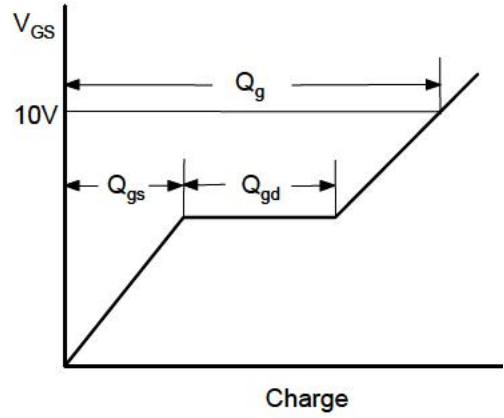
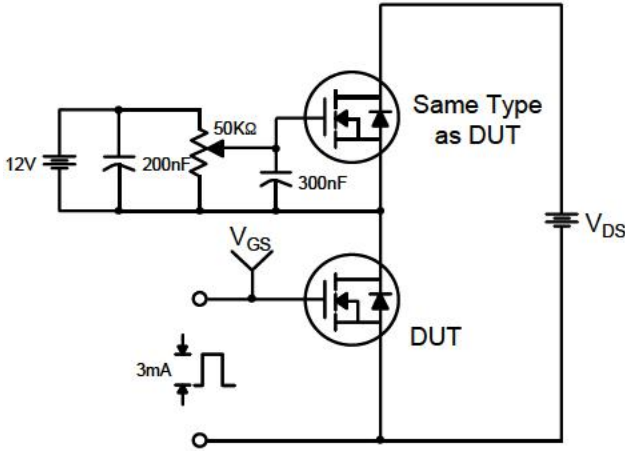
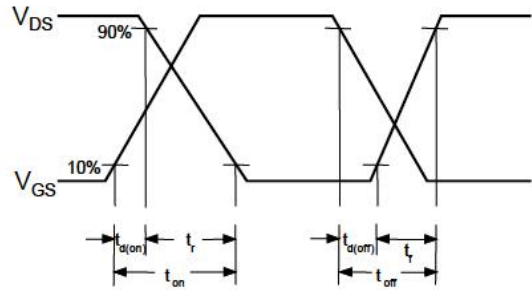
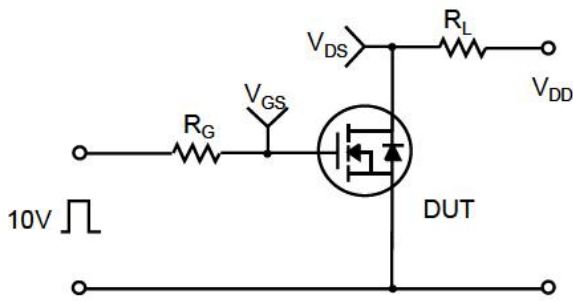

Figure 11. Transient Thermal Response Curve

Gate Charge Test Circuit & Waveform



Resistive Switching Test Circuit & Waveforms



Unclamped Inductive Switching Test Circuit & Waveforms

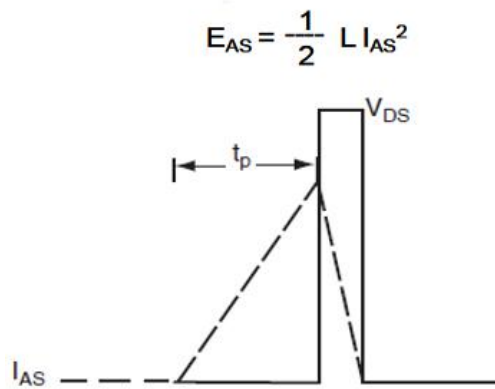
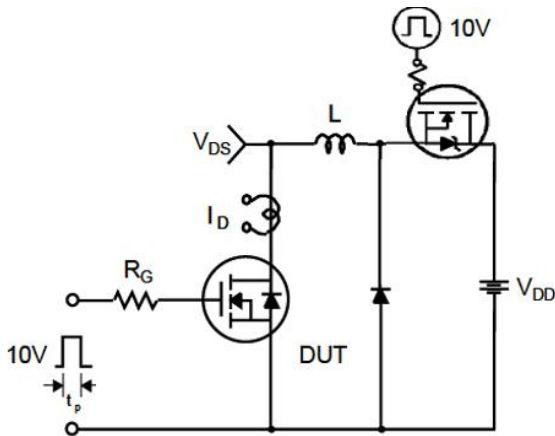

Peak Diode Recovery dv/dt Test Circuit & Waveforms

